

# NOTICES OF SUPPLEMENTAL PROPOSED RULEMAKING

After an agency has filed a Notice of Proposed Rulemaking with the Secretary of State's Office for *Register* publication and the agency decides to make substantial changes to the rule after it is proposed, the agency must prepare a Notice of Supplemental Proposed Rulemaking for submission to the Office, and the Secretary of State shall publish the Notice under the Administrative Procedure Act (A.R.S. § 41-1001 et seq.). Publication of the Notice of Supplemental Proposed Rulemaking shall appear in the *Register* before holding any oral proceedings (A.R.S. § 41-1022).

## NOTICE OF SUPPLEMENTAL PROPOSED RULEMAKING

### TITLE 17. TRANSPORTATION

#### CHAPTER 6. DEPARTMENT OF TRANSPORTATION

#### OVERDIMENSIONAL PERMITS

#### PREAMBLE

**1. Register citation and date for the original Notice of Proposed Rulemaking:**

8 A.A.R. 1657, April 5, 2002

**2. Sections Affected**

**Rulemaking Action**

R17-6-101	New Section
R17-6-102	New Section
R17-6-103	New Section
R17-6-104	New Section
R17-6-105	New Section
R17-6-112	New Section
R17-6-203	New Section
R17-6-204	New Section
R17-6-211	New Section
R17-6-305	New Section
R17-6-404	New Section
R17-6-405	New Section
R17-6-408	New Section
Illustration 3	New Illustration
R17-6-412	New Section
Table 4	New Table
R17-6-601	New Section
R17-6-602	New Section

**3. The specific authority for the rulemaking, including both the authorizing statute (general) and the statutes the rules are implementing (specific):**

Authorizing statute: A.R.S. § 28-366

Implementing statutes: A.R.S. §§ 28-1091 through 28-1100; 28-1103 through 28-1107; 28-1141 through 28-1149; and 28-7045

**4. The name and address of agency personnel with whom persons may communicate regarding the rule:**

Name: George R. Pavia, Department Rules Supervisor

Address: Administrative Rules Unit  
Department of Transportation, Mail Drop 507M  
3737 N. 7th Street, Suite 160  
Phoenix, AZ 85014-5079

Telephone: (602) 712-8446

Fax: (602) 241-1624

E-mail: gpavia@dot.state.az.us

Notices of Supplemental Proposed Rulemaking

Please visit the ADOT web site to track progress of this rule and any other agency rulemaking matters at [www.dot.state.az.us/about/rules/index.htm](http://www.dot.state.az.us/about/rules/index.htm).

**5. An explanation of the rule, including the agency's reasons for initiating the rulemaking:**

In a separate rulemaking, Motor Vehicle Division is repealing a set of archaic rules that were developed incrementally to regulate overdimensional permits statewide (original R17-4-406 through R17-4-428, subsequently renumbered as R17-4-450 through R17-4-467). At the same time as the repeal action, this new set of streamlined rules completely rewrites the rules regarding overdimensional permits as a new and separate Chapter (6) under 17 A.A.C. The result is a more practical and understandable set of rules for the regulated industry. The new rule format will be less difficult to amend as provision changes occur. Agency Enforcement will find the new Chapter more versatile for ease in reference and distribution to interested parties. This undertaking is a collaborative effort between Motor Vehicle Division Central Permits section, ADOT Intermodal Transportation Division, the state's Overdimensional Permit Advisory Council, and interested parties from the commercial transport industry.

**Notes to the reader:** This notice officially reopens the public record first established the Notice of Proposed Rulemaking, published as indicated in preamble item #1. The Notice of Proposed Rulemaking and this supplemental notice must be read together. Only Sections with changes appear in this notice. Any Section from the Notice of Proposed Rulemaking that does not appear in this supplemental notice will be carried forward without change to the Notice of Final Rulemaking. The agency's response to formal public comment received on the Notice of Proposed Rulemaking does not appear in this notice. The response to all comments made on the Notice of Proposed Rulemaking and the Notice of Supplemental Proposed Rulemaking will be incorporated into the Notice of Final Rulemaking. In the interim, the agency's response to comments received on the Notice of Proposed Rulemaking is posted to the Overdimensional Permits page of the Administrative Rules Unit web site, address: [www.dot.state.az.us/about/rules/index.htm](http://www.dot.state.az.us/about/rules/index.htm).

**Section numbering:** Since the beginning of this rulemaking, the agency recodified the entirety of 17 A.A.C. The rule numbering scheme in the original Notice of Rulemaking Docket Opening was a range from R17-4-401 through R17-4-427.

**6. An explanation of the substantial change which resulted in this supplemental notice:**

**R17-6-101(B)(12)(d).** An "applicant-burden-of-proof" clause was added for clarity in the 8-hour-dismantle provision in the definition of a "fixed load." This language is already present as a federal requirement in 23 CFR 658.5.

**R17-6-101(B)(18).** Curfew boundaries for Metropolitan Phoenix were returned to coordinates in effect before the initiation of this rulemaking. State routes 51, 143, 153, and 202 were left in the curfew-designated area since they are either completely encompassed by curfewed highways or have not been a point of controversy in the rulemaking.

**R17-6-102(A).** An additional citation, A.R.S. § 28-1093(D), was added to provide specific exemption of non-commercial use recreational vehicles from having to obtain overdimensional permits.

**R17-6-102(D).** The agency added subsection (D) since an overdimensional permit is not necessary for a vehicle crossing a state highway at a grade that does not involve crossing a structure.

**R17-6-103(C).** For purposes of submitting the dimensions of a vehicle and load, the agency changed "exact dimensions" to require the dimensions of a specified load.

**R17-6-103(J).** The agency added the statutory citation requiring a utility company be notified of possible disturbance or damage.

**R17-6-104. Special Class C Permit Application Procedure.** The agency amended the Section as follows: Subsection (A) has as a general requirement, any applicant for a class C permit must submit dimensions of a vehicle and load, and the proposed route. Subsection (A)(2)(a)(iv) clarifies that the width of the axle measurement does not include the tire bulge. Subsection (B) requires additional applicant information for an overweight class C permit. Subsections (B) and (C) change the process and payment amount for an engineering analysis. Subsection (D) clarifies that an applicant can use a previously-approved engineering analysis for an identical vehicle, load, and route.

**R17-6-105(B).** The agency deleted this subsection to allow for "back-hauling", or allowing overdimensional vehicles to return to the point of origin with loads that are not over legal dimensions.

**R17-6-112. Emergency Operation Provision.** In response to public comment, the agency added this Section to provide for specially authorized transport without an overdimensional permit in cases of emergency that imperil public safety or welfare.

**R17-6-203. Class B, Type R.** The permit option language was enhanced to further clarify an individual permit's validity and applicability for a permit holder usage.

**R17-6-204. Class C.** The agency added new flat rate payment provisions instead of having an hourly rate for ADOT

Notices of Supplemental Proposed Rulemaking

to conduct or review, or both, the engineering analysis for an overweight vehicle or load.

**R17-6-211. Manufactured Home Permit Book.** The agency is deleting this Section in its entirety along with any citation to R17-6-211 throughout the Chapter because of a court ruling that MVD's self-issue permit procedure exceeds statutory authority under A.R.S. §§ 28-1103 and 28-1104. Previously, MVD has allowed mobile home transporters to apply for and purchase books of blank permits for self-issuance before each individual move. This procedure, however, does not require the transporter to provide a specific description of a vehicle or load to be operated or moved and the particular highways for which the permit to operate is requested at the time of application, as required under A.R.S. § 28-1104(A). Therefore, the agency must discontinue the self-issue permit procedure. Future transport of manufactured housing will be governed by the rules and procedures for class A or C permits. Information and implementation of the discontinuance of manufactured housing self-issue permits is contained in MVD policy memo 02-026, effective October 1, 2002.

**R17-6-305(B). Escort Vehicles.** In response to public comment, the agency has modified (B)(2)(d)(ii) to clearly require radio communication between each escort vehicle and each overdimensionally-permitted vehicle under escort.

**R17-6-404. Urban Transport.** Curfew hours for Metropolitan Phoenix were returned to times in effect before the initiation of rulemaking.

**R17-6-405. Weekend Transport.** The agency added the phrase to subsection (C) "...except as allowed under subsection (A)."

**R17-6-408. Continuous Travel.** The agency made technical corrections by amending subsection (A) to add dimensions other than width for continuous travel. The agency also amended subsection (B) to clarify that continuous travel is allowed only for a vehicle not exceeding the stated dimensions, and not during the urban curfew.

**Illustration 3: Overweight Axle Groups.** A note concerning method of tire-width measurement was deleted since it was inconsistent with R17-6-104(A)(2)(a)(iv).

**R17-6-412. Highway-specific Overdimensional Permitted Vehicle Restrictions.** The agency updated the ADOT web site address based on ADOT's new use of the 511 information system, and district office telephone numbers.

**Table 4. Permanent Overdimensional Vehicle Highway Restrictions.** The agency corrected errors on State Route 90, changed the listing for US Route 89 and 89A to State Route 89 and 89A where needed, and deleted references to R17-6-211.

**Article 6. Manufactured Home Permit Special Provisions:** With the elimination of manufactured home self-issue permits, the two sections constituting this entire Article are also no longer applicable and are therefore deleted.

The agency also attempted to improve clarity and consistency throughout all the sections by amending language that lists or describes a dimensional requirement. Also global non-substantial changes in grammar, syntax, and stylistics were included according to known standards of the Governor's Regulatory Review Council and the Secretary of State.

**7. A showing of good cause why the rule is necessary to promote a statewide interest if the rule will diminish a previous grant of authority of a political subdivision of this state:**

Not applicable

**8. The preliminary summary of the economic, small business, and consumer impact:**

This rulemaking updates the current rules for clarity, decreasing the cost of agency, permittee, and small business along with political subdivisions. Agency, permittee, and small business along with political subdivisions will benefit by rules that will allow for quicker and easier understanding of the requirements of overdimensional permit rules. The agency incorporated global non-substantial changes in grammar, syntax, and word choice to improve the rule's clarity, conciseness, and understandability. The agency also eliminated provisions that duplicated requirements in statute.

The agency may incur initial set up costs for administrative procedures. However, the costs should be minimal as Arizona Central Commercial Permits and MVD Enforcement already are required to provide permits for overdimensional vehicle travel across the roads that the agency maintains.

The permittee and small businesses may incur initial set up costs for administrative procedures. However, this should be minimal as both the permittee and small businesses already are required to request permits to move their overdimensional loads over the roads that the agency maintains.

The agency has removed some requirements that will have value added savings to the permittee and small businesses in the removal of some fees and allowing for greater movement times. State revenues will not see any loss in the elimination of some fees that were not collected. The state is conforming to similar rules to contiguous states that bor-

Notices of Supplemental Proposed Rulemaking

der with Arizona to make it easier for permittees and small businesses to move their loads through the state. The agency will benefit in the new rulemaking to allow for better budget planning and enforcement of the rules. The agency will benefit in improving their processes involved in application assessment and approval due to the new rules. The Arizona Department of Public Safety (DPS), that enforces the rules on the highways, will benefit in improving their processes involved in enforcement of the overdimensional vehicles that they encounter on the roads of Arizona. Overall, the agency believes that there will be an inestimable benefit to all citizens of Arizona due to statewide motoring safety and highway structural integrity.

**9. The name and address of agency personnel with whom persons may communicate regarding the accuracy of the economic, small business, and consumer impact statement:**

Name: Brent P. Heiss, Rules Analyst  
Address: Administrative Rules Unit  
Department of Transportation, Mail Drop 507M  
3737 N. 7th Street, Suite 160  
Phoenix, AZ 85014-5079  
Telephone: (602) 712-8449  
Fax: (602) 241-1624  
E-mail: bheiss@dot.state.az.us

**10. The time, place, and nature of the proceedings for the adoption, amendment, or repeal of the rule or, if no proceeding is scheduled, where, when, and how persons may request an oral proceeding on the proposed rule:**

The agency held an oral proceeding on May 7, 2002 pertaining to the original Notice of Proposed Rulemaking. This supplemental notice incorporates the agency's response to public comment received concerning the original Notice of Proposed Rulemaking.

An oral proceeding **ONLY on the changes introduced in this Notice of Supplemental Proposed Rulemaking** will be held as follows:

Date: Tuesday, November 19, 2002  
Time: 1:00 p.m.  
Location: ADOT Auditorium  
206 S. 17th Avenue  
Phoenix, AZ 85007

Closure: The agency official listed in item #4 will receive written comments on the provisions incorporated in this notice from the time of the notice's publication until 4:30 p.m. on Friday, November 22, 2002 at which time the public record will close.

**11. Any other matters prescribed by statute that are applicable to the specific agency or to any specific rule or class of rules:**

Not applicable

**12. Incorporations by reference and their location in the rules:**

None

**13. The full text of the changes follows:**

**TITLE 17. TRANSPORTATION**

**CHAPTER 6. DEPARTMENT OF TRANSPORTATION**

**OVERDIMENSIONAL PERMITS**

**ARTICLE 1. GENERAL PROVISIONS**

Section

- R17-6-101. Definitions
- R17-6-102. Threshold Dimensions
- R17-6-103. General Permit Application Procedure
- R17-6-104. Special Class C Permit Application Procedure
- R17-6-105. Permit Limitation
- R17-6-112. Emergency Operation Provision

Notices of Supplemental Proposed Rulemaking

**ARTICLE 2. PERMIT CLASSES**

- R17-6-203. Class B, Type R
- R17-6-204. Class C
- R17-6-211. ~~Manufactured Home Permit Book~~

**ARTICLE 3. SAFETY RESTRICTIONS**

- R17-6-305. Escort Vehicles

**ARTICLE 4. TRANSPORT RESTRICTIONS**

- R17-6-404. Urban Transport
- R17-6-405. Weekend Transport
- R17-6-408. Continuous Travel
- Illustration 3. Overweight Axle Groups
- R17-6-412. Highway-specific Overdimensional Permitted Vehicle Restrictions
- Table 4. Permanent Overdimensional Vehicle Highway Restrictions

**ARTICLE 6. MANUFACTURED HOME PERMIT SPECIAL PROVISIONS**

- R17-6-601. Self-issue Prepaid Permit Enforcement
- R17-6-602. Penalties

**ARTICLE 1. GENERAL PROVISIONS**

**R17-6-101. Definitions**

- A.** The Division Director of the Arizona Department of Transportation, Motor Vehicle Division in cooperative partnership with the Intermodal Transportation Division, shall issue and regulate overdimensional permits under this Chapter. The agency implements these Sections under general authority of A.R.S. § 28-1103(B) and in collaboration with the Overdimensional Permit Advisory Council as prescribed under A.R.S. § 28-1150(C)(3).
- B.** The following definitions apply to this Chapter:
  - 1. "AASHTO" means American Association of State Highway and Transportation Officials.
  - 2. "ADOT" or "Department" means Arizona Department of Transportation.
  - 3. "Appurtenance" means any not-readily-removable manufacturer- or dealer-installed fixture attached to a vehicle or load that increases a peripheral dimension of the vehicle or load.
  - 4. "Arizona Central Commercial Permits" means the statewide ADOT-MVD headquarters office for overdimensional permit applications and information; address:  
14370 West Van Buren  
Goodyear, Arizona 85338  
voice line: (623) 932-2247  
facsimile: (623) 932-2441  
internet: [www.dot.state.az.us/mvd/centralpermits/index.htm](http://www.dot.state.az.us/mvd/centralpermits/index.htm)
  - 5. "Articulated (combination) vehicle" means any combination of a truck or truck tractor and one or more trailers or semitrailers that operates so that two or more frames are connected by suitable couplings, but does not include a manufactured or mobile home.
  - 6. "Continuous travel" means to operate a vehicle continuously throughout any 24-hour period.
  - 7. "Director" means:
    - a. The Division Director of the Arizona Department of Transportation, Motor Vehicle Division; or
    - b. The Division Director's designee.
  - 8. "Division" or "MVD" means the Arizona Department of Transportation, Motor Vehicle Division.
  - 9. "Envelope" has the meaning prescribed under A.R.S. § 28-1141(1) and for clarity is further defined as a specific set of load dimensional criteria applicable to issuing an envelope permit as follows:
    - a. No longer than 120 feet.
    - b. No taller than 16 feet.
    - c. No wider than 14 feet.
    - d. No heavier than 250,000 pounds gross weight and does not exceed axle group weight distribution as prescribed under R17-6-411 – Table 3.01 through Table 3.09, and
    - e. No fewer than 4 axles.
  - 10. "Envelope permit" has the meaning prescribed under A.R.S. § 28-1141(2) and for clarity is further defined as an overdimensional permit issued as a convenience to an intrastate carrier that:
    - a. Is restricted to non-reducible loads.
    - b. Allows unlimited trips within the permit's validity period.
    - c. Allows the permitted carrier unlimited load changes.
    - d. Requires a transported load to meet envelope dimensional criteria, and

**Notices of Supplemental Proposed Rulemaking**

- e. Restricts operation to certain routes.
- 11. “Established place of business” means a permanent site or location where the business of an oversized permit holder is conducted.
- 12. “Fixed load”, “non-reducible load”, “non-divisible load”, or “non-divisible vehicle” have the meaning prescribed under 23 CFR 658.5 April 2001, and for purposes of clarity in this Chapter mean an oversized load or vehicle that if separated into smaller components would:
  - a. Compromise intended use,
  - b. Destroy load or vehicle value,
  - c. Render a load or vehicle unusable for its intended purpose, or
  - d. Require more than 8 hours to dismantle using appropriate equipment with the burden of proof on the permit applicant as to the number of dismantle hours necessary.
- 13. “Highway feature” means a roadway, structure, traffic control device, right-of-way, or other accessory connected with highway travel.
- 14. “ITD” means Intermodal Transportation Division.
- 15. “LCV” or “longer combination vehicle” means any combination of a truck or truck tractor and 1 or more trailers or semitrailers that operates at a gross vehicle weight ~~greater than~~ exceeding 80,000 pounds.
- 16. “Maintenance Permits Services” means Arizona Department of Transportation Intermodal Transportation Division headquarters office for class C oversized permit approval and technical information; address: 206 South 17th Avenue, Mail Drop 004R Phoenix, Arizona 85007 voice line:(602) 712-8280 or 8176 facsimile:(602) 712-3380
- 17. “Manufactured home” has the meaning prescribed under A.R.S. § 41-2142(2) and (24).
- 18. “Metropolitan Phoenix” means linear distance on a federal or state highway between post markers as designated:

<u>Highway type</u>	<u>Highway number</u>	<u>Post marker and street name coordinate range</u>
<u>Interstate</u>	<u>10</u>	<u>133A – 99th Avenue to <del>164 – Queen Creek</del> 161 – Chandler Boulevard</u>
<u>Interstate</u>	<u>17</u>	<u><del>216A – SR101</del> 217 – Pinnacle Peak Road to 150A – I-10 junction at 24th Street</u>
<u>State route</u>	<u>51</u>	<u>All</u>
<u>US route</u>	<u>60</u>	<u><del>138.6 – Loop 303 to 195 – Ironwood</del> 188 – Power Road to 172 – I-10 junction</u>
<u><del>State route</del></u>	<u><del>101</del></u>	<u>All</u>
<u>State route</u>	<u>143</u>	<u>All</u>
<u>State route</u>	<u>153</u>	<u>All</u>
<u>State route</u>	<u>202</u>	<u>All</u>

- 19. “Metropolitan Tucson” means linear distance on a federal or state highway between post markers as designated:

<u>Highway type</u>	<u>Highway Number</u>	<u>Post marker and street name coordinate range</u>
<u>Interstate</u>	<u>10</u>	<u>242.5 – Cortaro Road to 268 – Craycroft Road</u>
<u>Interstate</u>	<u>19</u>	<u>95 – Valencia to I-10 junction</u>

**Notices of Supplemental Proposed Rulemaking**

<u>State route</u>	<u>77</u>	<u>82 – Tangerine Road to I-10 junction</u>
<u>State route</u>	<u>86</u>	<u>166.5 – Kinney Road to I-19B junction</u>

- 20. “Mobile home” has the meaning prescribed under A.R.S. § 28-2001(B)(1).
- 21. “M.S.T.” or “Mountain Standard Time” means the time in Arizona as prescribed under 49 CFR 71.2(b) and A.R.S. § 1-242(A), rejecting the adoption of daylight saving time as prescribed under A.R.S. § 1-242(C) permitted under 49 CFR 71.2.
- 22. “Overdimensional” means any size or weight measurement exceeding a measurement prescribed under R17-6-102, Table 1.
- 23. “Permit supervisor” means a managing official of Arizona Central Commercial Permits or a port of entry daily officer-in-charge.
- 24. “Permittee” means a person possessing an overdimensional permit.
- 25. “Power unit” has the meaning prescribed in A.R.S. § 28-1141(3).
- 26. “Specified load” means any item or series of items transported throughout an entire permit period with no alteration except for exact dimensional duplicate item substitution.
- 27. “Sunrise” and “Sunset” have the meaning and daily calculation prescribed by the United States Naval Observatory “USNO” that:
  - a. The Department uses to determine normal permit transport start and stop times as prescribed under R17-6-401(A); and
  - b. An interested person may obtain from the USNO internet address: <http://aa.usno.navy.mil> or in hardcopy from the Department office prescribed under R17-1-101(B)(19)(4).
- 28. “Tandem axle” has the meaning prescribed in A.R.S. § 28-1100(B).
- 29. “Tare weight” means a vehicle’s empty or starting weight.
- 30. “Vehicle combination” has the meaning prescribed under A.R.S. § 28-101(10).

**R17-6-102. Threshold Dimensions**

- A.** Unless a vehicle is exempt under A.R.S. § 28-1091(C) or 28-1093(D), a vehicle operator shall have an overdimensional permit for a vehicle or load exceeding any dimension prescribed in Table 1.
- B.** A vehicle required to carry an overdimensional permit as prescribed under subsection (A) shall comply with any applicable:
  - 1. Safety requirement prescribed under Article 3 of this Chapter, and
  - 2. Transport restriction prescribed under Article 4 of this Chapter.
- C.** The Department shall require a class C permit for an overdimensional vehicle or load over axle weight or heavier than 250,000 pounds that proposes a transport route that crosses any bridge over a state or federal highway.
- D.** An overdimensional vehicle or load does not require an overdimensional permit if crossing a state highway at a grade.

**R17-6-103. General Permit Application Procedure**

- A.** To obtain a permit under Section R17-6-210 ~~or R17-6-211~~, a person shall submit a completed application form to the Arizona Central Commercial Permits office at the location prescribed under R17-6-101(B)(4).
- B.** Except for Section R17-6-204, the Department shall issue a permit under Sections R17-6-201 through R17-6-209 according to the point-of-application local office procedure by one of the following methods:
  - 1. Written application form, or
  - 2. Direct electronic data entry of required applicant information by an authorized Department officer.
- C.** An applicant shall submit exact dimensions of the for a vehicle plus specified load combination.
- D.** The Department shall not approve an overdimensional permit application for a vehicle subject to registration under A.R.S. § 28-2153 unless the vehicle has valid registration with the ~~Motor Vehicle~~ Division.
- E.** An applicant for transport of a manufactured home under a class A; or C; ~~or Manufactured Home Permit Book~~ shall present Ad Valorem tax clearance to the Department at the time of issuance.
- F.** If an overdimensional permit applicant must temporarily move any state-owned highway feature as part of a planned move, the applicant shall also obtain any applicable encroachment permit according to procedure prescribed under R17-3-702 before issuance of an overdimensional permit.
- G.** If there are reasonable grounds to question weight accuracy of an applicant’s vehicle, the Department shall require the vehicle to be weighed by a certified weighmaster before issuing a permit. To facilitate applicant compliance with this subsection, the Department shall issue a temporary permit for the applicant to access a weighmaster service.
- H.** If the Department determines traffic control is necessary for an applicant-vehicle’s proposed trip route, the applicant shall comply with safety requirements prescribed under R17-6-306.

Notices of Supplemental Proposed Rulemaking

- I. Falsification of any application information is grounds for permit denial.
- J. If overhead lines cross the proposed route of an applicant's overheight vehicle or load, as prescribed in R17-6-102 – Table 1, the applicant shall notify the responsible utility company of possible disturbance or damage as required by A.R.S. § 40-360.43.

**R17-6-104. Special Class C Permit Application Procedure**

- A. An applicant shall submit a written application for a class C permit to ADOT-ITD Maintenance Permits Services at the address prescribed under R17-6-101(B)(15)(16). ~~An applicant shall submit a written application on:~~
  - 1. An applicant shall submit a written application on ~~The~~ the applicant's letterhead; or an application form provided by the ADOT-ITD Maintenance Permits ~~Section~~ Services.
  - 2. An application form provided by the ADOT-ITD Maintenance Permits ~~Section~~. The application shall contain the following:
    - a. Overall dimensions for a vehicle plus its specified load:
      - i. Length,
      - ii. Height,
      - iii. Width, and
      - iv. Width to the outside of axles, not including load-induced tire bulge, and
    - b. A detailed route description or printed map with intended route clearly marked to indicate where a permittee will enter and exit the highway system, and calculating total mileage.
- B. Application for an overweight class C permit. If an applicant's vehicle exceeds weight limits prescribed under R17-6-411 - Table 3.01 through 3.09, or exceeds 250,000 pounds, the applicant shall provide the following along with a written permit application:
  - 1. Vehicle axle spacings; .
  - 2. Axle weights; .
  - 3. Exact overall dimensions of the for a vehicle plus its load:
    - a. Length;
    - b. Height;
    - c. Width; and
    - d. Width to the outside of axles, not including load-induced tire bulge;
  - 4. Tires:
    - a. Manufacturer-designated width; . and
    - b. Number per axle; .
  - ~~5.4. Load weight; .~~
  - ~~6.5. Tare weight; .~~
  - ~~7.6. A load's loaded position; and .~~
  - 8. A detailed route description or printed map with intended route clearly marked to indicate where a permittee will enter and exit the highway system, and calculating total mileage.
  - ~~9.7. An engineering analysis, and~~
  - ~~10.8. Payment for an engineering analysis as prescribed in R17-6-204.~~
- C. Engineering analysis.
  - 1. The applicant shall submit an engineering analysis if the weight of a vehicle or load exceeds:
    - a. 250,000 pounds, or
    - b. The maximum permitted weights prescribed in R17-6-411 and Table 3.01 through 3.09.
  - 2. The engineering analysis shall describe and certify that on a proposed route an applicant's overweight vehicle will not damage:
    - a. A highway structure; or
    - b. Any other state property.
  - 3. An engineer shall prepare an engineering analysis. As prescribed under 4 A.A.C. 30, the engineer shall be registered:
    - a. By the Arizona Board of Technical Registration, and
    - b. In the structural or civil branch of engineering.
  - 4. The applicant may request that the Department prepare the engineering analysis. The applicant shall pay for the costs of the engineering analysis at a rate of \$75 per hour.
  - 1. An engineer shall prepare an engineering analysis. As prescribed under 4 A.A.C. 30, the engineer shall be registered:
    - a. By the Arizona Board of Technical Registration, and
    - b. In the structural or civil branch of engineering.
  - 2. An engineer shall prepare an engineering analysis according to the following technical standards:
    - a. The current AASHTO edition of the Condition Evaluation of Bridges including all interims,
    - b. The current AASHTO edition of the Standard Specifications for Highway Bridges including all interims,
    - c. The ADOT Bridge Practice Guidelines, and
    - d. Any applicable standards or guidelines referred to in subsections (C)(2)(a) through (c).



**Notices of Supplemental Proposed Rulemaking**

- 3. An engineer shall describe and certify that on a proposed route an applicant's overweight vehicle will not overstress or damage any element of:
  - a. A highway structure; or
  - b. Any other state property.
- 4. The applicant may request that the Department prepare the engineering analysis. The Department may decline to prepare an engineering analysis and request that the applicant submit an engineering analysis prepared by a non-Department engineer if the Department lacks employee resource availability.
- D.** An applicant for a subsequent class C permit may resubmit ~~a pre-existing independent~~ an engineering analysis previously approved by to the Department if: ~~the applicant's vehicle or load dimensions and proposed route are identical to a previously approved permit application.~~
  - 1. The applicant's vehicle or load dimensions and proposed route are identical to a previously approved permit application, and
  - 2. There has been no change in condition to a highway structure or other state property.
- E.** The Department shall conduct a separate analysis and approval procedure for each engineering analysis submitted under this Section.
- F.** Denial of an engineering analysis constitutes denial of the application for class C permit.

**R17-6-105. Permit Limitation**

- ~~A.~~** An overdimensional permit authorizes transport only on a state or federal highway. A permittee shall apply separately with an applicable political subdivision or tribal nation for permission to operate on a county, municipal, or tribal route.
- ~~B.~~** The Department shall not issue a permit to transport a load less than a threshold dimension prescribed under R17-6-102 – Table 1 on an overwidth trailer.

**R17-6-112. Emergency Operation Provision**

In time of statewide or local emergency that affects public welfare or safety, according to general powers granted to the Director under A.R.S. §§ 28-363(A)(5) and 28-364(B), the Director may authorize movement of an overdimensional vehicle or load without a permit for purposes of relief or repair.

**ARTICLE 2. PERMIT CLASSES**

**R17-6-203. Class B, Type R**

MVD shall issue a class B, Type R permit according to the following schedule:

<u>Vehicle-load description</u>	<u>A commercial transporter hauling or driving a recreational vehicle with appurtenances wider than 8'6"</u>
<u>Permit option</u>	<u><del>25 original multiple trip permits with a one-year validity</del> One original permit per entity with an option of up to 24 additional copies valid for unlimited use throughout a one-year period</u>
<u>Fee</u>	<u>\$360</u>

**Notices of Supplemental Proposed Rulemaking**

**R17-6-204. Class C**

MVD shall issue a class C permit according to the following schedule:

<u>Vehicle-load description</u>	<u>A non-reducible load that exceeds dimensions and weights of all other permit classes or proposes operation on a restricted route.</u>	
<u>Permit option – requires pre-approval by ADOT-ITD Maintenance Permits Services</u>	<u>Specific applicant-designated load as required under R17-6-104(B)</u>	<u>Single trip only</u>
<u>Standard permit fee</u>	<u>Single trip. height or width no greater than 18’</u>	<u>\$15. plus \$15 service charge</u>
	<u>Single trip. height or width <del>greater than</del> exceeding 18’</u>	<u>\$15. plus \$25 service charge</u>
<u>Overweight permit fee</u>	<u>Single trip height or width no greater than 18’</u>	<u>\$75. plus \$15 service charge</u>
	<u>Single trip. height or width <del>greater than</del> exceeding 18’</u>	<u>\$75. plus \$25 service charge</u>
<u>Engineering Analysis</u>	<u>Prepared and reviewed by ADOT engineer</u>	<u>\$125 per 50 mile increment of proposed route</u>
	<u>Prepared by non-ADOT engineer, and reviewed by ADOT engineer</u>	<u>\$75 per 50 mile increment of proposed route</u>

**Notices of Supplemental Proposed Rulemaking**

**R17-6-211. Manufactured Home Permit Book**

**A:** ~~MVD shall issue a book of manufactured home transport permits according to the following schedule:~~

<del>Vehicle load description</del>	<del>A self issued manufactured home over legal threshold as prescribed under R17-6-102 - Table 1 to a maximum:</del>	
	<del>Height</del>	<del>16'</del>
	<del>Overall length</del>	<del>120'</del>
	<del>Width</del>	<del>16'</del>
	<del>Weight</del>	<del>80,000 lbs.</del>
<del>Permit period</del>	<del>A voucher book of 50 single trips</del>	
<del>Fee</del>	<del>\$750</del>	

**B:** ~~Travel restrictions. A permittee under this Section shall restrict transport as follows:~~

- ~~1. For a permittee of a manufactured home up to 14 feet wide, all highway restrictions prescribed under R17-6-412 – Table 4 apply.~~
- ~~2. For a permittee of a manufactured home with dimensions from 14 feet, 1 inch to 16 feet wide, the Special Movement column prescribed under R17-6-412 – Table 4 applies. The permittee shall be accompanied by a front and a rear escort.~~
- ~~3. If a transporter of a manufactured home with dimensions from 14 feet, 1 inch to 16 feet intends to transport on any highway not prescribed under R17-6-412 – Table 4 Special Movement column, the transporter shall apply for a permit under R17-6-204.~~

**C:** ~~Special limitation. No permittee shall use a permit issued under this section for operation on a highway under construction or repair unless the permittee obtains specific clearance from an ADOT highway project engineer for a permittee's proposed route as prescribed under R17-6-412(B)(2).~~

**D:** ~~Permit distribution. When a permittee uses a three-part self-issue manufactured home permit, the permittee shall:~~

- ~~1. Attach the white original manufactured home permit so it is clearly visible from a transported manufactured home's:
 
  - ~~a. Rear window, or~~
  - ~~b. Rearmost left-side window if the transported manufactured home has no rear window;~~~~
- ~~2. Mail the following to the address prescribed under R17-6-101(B)(4):
 
  - ~~a. The yellow duplicate copy manufactured home permit, and~~
  - ~~b. Any county assessor issued clearance form indicating permittee payment of Ad Valorem taxes and fees;~~~~
- ~~3. Retain the pink triplicate copy manufactured home permit in original booklet binding at the permittee's established place of business.~~

**ARTICLE 3. SAFETY REQUIREMENTS**

**R17-6-305. Escort Vehicles**

**A.** Service requirement.

1. When required by the Department, a permittee of an overdimensional vehicle or load shall have escort vehicle accompaniment when transporting on a highway prescribed under R17-6-412 – Table 4.
2. The Department shall base its decision to require an overdimensional permitted vehicle to be accompanied by one or more escort vehicles on:
  - a. Proposed transport route:
    - i. Highway width,
    - ii. Surface condition, and
    - iii. Grade,
  - b. Load size,
  - c. Need for frequent stops, or
  - d. Concern for public safety.
3. In accordance with the criteria applicable under subsection (A)(2), the Department shall require 2 two or more overdimensional permitted vehicles travelling together to be accompanied by at least 1 one escort vehicle per load.

Notices of Supplemental Proposed Rulemaking

**B. Vehicle qualification and equipment.**

1. A vehicle qualifies as an escort vehicle if it:
  - a. Is a passenger car or ~~2-axle~~ two-axle truck not exceeding 20,000 pounds, and
  - b. Has valid vehicle registration.
2. An escort vehicle operator shall possess:
  - a. Warning flags for an overdimensional vehicle or load:
    - i. Manufactured to specifications prescribed under R17-6-302(A), and
    - ii. Displayed as prescribed under R17-6-302(B).
  - b. Warning lights as prescribed under A.R.S. § 28-947(D).
  - c. An "OVERSIZE LOAD" sign:
    - i. Constructed as prescribed under R17-6-303(C),
    - ii. Mounted above the vehicle's roofline,
    - iii. Displayed as prescribed under R17-6-303(D), and
    - iv. Not visible when not in use.
  - d. A ~~2-way~~ two-way radio:
    - i. Capable of transmitting and receiving a minimum of ~~1/2~~ one-half mile, and
    - ii. Compatible with each ~~2-way~~ two-way radio in an accompanying escort ~~or towing~~ and each escorted overdimensionally-permitted vehicle.
  - e. Emergency equipment as follows:
    - i. No fewer than ~~8~~ eight flares; and
    - ii. Two emergency staff-mounted warning flags manufactured to specifications prescribed under R17-6-302(A).

**C. Operation.**

1. Lighting requirement. While in service, an escort vehicle operator shall maintain continuous illumination of headlights and warning lights.
2. Lead- and follow-distance.
  - a. On an open highway, except when visual contact cannot be maintained, an escort vehicle operator shall maintain a lead- or follow-distance ~~of no greater than~~ not exceeding 1,000 feet from the escorted vehicle.
  - b. In an urban setting, an escort vehicle operator shall maintain a lead- or follow-distance ~~of no greater than~~ not exceeding 250 feet from the escorted vehicle.
3. Stop provisions at a traffic signal-controlled intersection.
  - a. When a load-bearing vehicle is required to stop, the lead-escort vehicle operator shall stop safely on the right-hand roadside after proceeding through the intersection. The lead-escort vehicle operator shall resume normal lead distance after the load-bearing vehicle clears the intersection.
  - b. When a following-escort vehicle is required to stop, the operator of a load-bearing vehicle shall proceed without stopping. The following-escort vehicle operator shall resume its normal distance behind the load-bearing vehicle after clearing an intersection.

**ARTICLE 4. TRANSPORT RESTRICTIONS**

**R17-6-404. Urban Transport**

No permittee of a vehicle or load wider than ~~40~~ ten feet shall transport on a non-holiday Monday through Friday in:

1. Metropolitan Phoenix as defined under R17-6-101(B)(~~17~~)(18) during the following hours, M.S.T. as defined under R17-6-101(B)(~~20~~)(21):
  - a. ~~6~~ 7 to 9 a.m., and
  - b. 4 to ~~7~~ 6 p.m.
2. Metropolitan Tucson as defined under R17-6-101(B)(~~18~~)(19) during the following hours, M.S.T. as defined under R17-6-101(B)(~~20~~)(21):
  - a. 7 to 9 a.m., and
  - b. 4 to 6 p.m.

**R17-6-405. Weekend Transport**

**A. This Section applies to a vehicle or load that does not exceed any of the following dimensions dimension as follows:**

1. 16 feet wide;
2. 16 feet high;
3. 120 feet long; and
4. 250,000 pounds.

**B. A permittee of a vehicle or load with dimensions less than or equal to those that does not exceed any dimension prescribed under subsection (A) may transport:**

1. On any non-holiday weekend Saturday or Sunday;
2. From 3 a.m. until noon M.S.T.;
3. On selected routes as prescribed under R17-6-412 – Table 4; and

**Notices of Supplemental Proposed Rulemaking**

4. With applicable escort accompaniment as prescribed under R17-6-409(C).  
**C.** A permittee of a vehicle or load with dimensions greater than exceeding those prescribed under R17-6-201 shall not transport on a Saturday or Sunday, except as allowed under subsection (A).

**R17-6-408. Continuous Travel**

- A.** A permittee The Department shall allow continuous travel of an overdimensional vehicle or load that is does not exceed 10 ten feet wide or less may operate with continuous travel, with all other dimensions not to exceed those in Table 1.  
**B.** A Except as prescribed under R17-6-404, the Department shall allow continuous travel of a permittee of an overdimensional vehicle or load that does not exceed with dimensions less than those prescribed below may operate with continuous travel except as prescribed under R17-6-404. any dimension as follows:  
 1. 10 feet, 1 inch wide,  
 2. 14.6 feet high,  
 3. 10 feet long in front- or rear-overhang, or  
 4. Longer than 120 feet overall.  
**C.** Except during any time and location prohibited under R17-6-405 and R17-6-406, the Department shall allow continuous travel of a crane permitted as prescribed under R17-6-205 that does not exceed any of the following dimensions dimension as follows:  
 1. 11 feet wide;  
 2. 14 feet high; and  
 3. 10 feet in overhang.

**Illustration 3: OVERWEIGHT AXLE GROUPS**

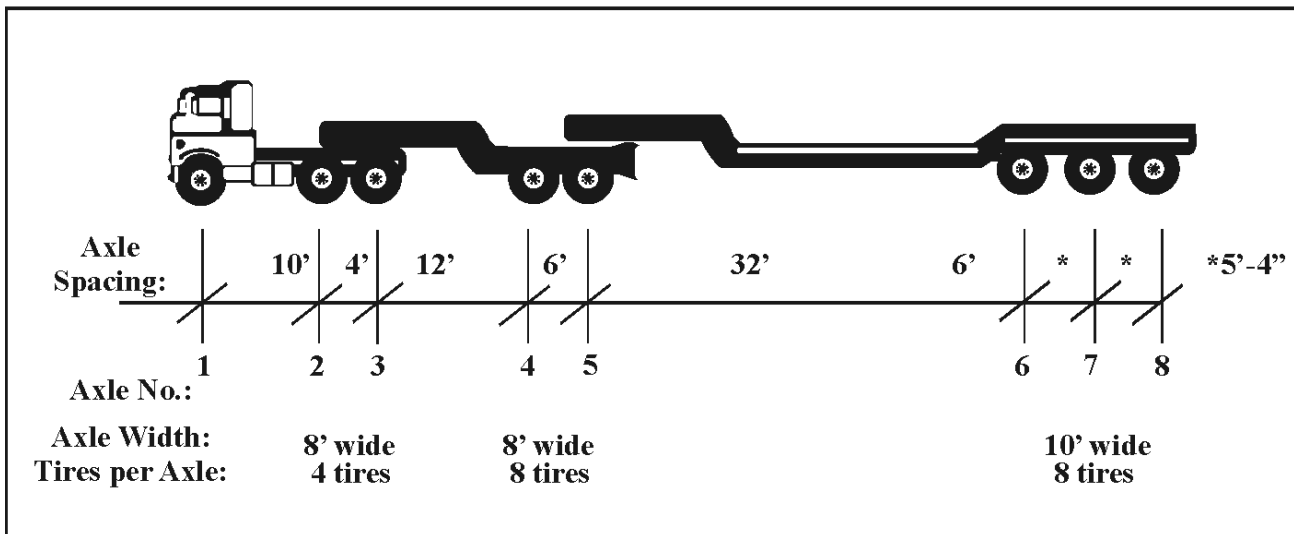

The axle group weights shown on the previous tables are maximum weights allowed on any combination of axles within the distance between the front and rear axle of a given group up to a maximum of 18 feet. The values in table 3.01 line "A" are an expansion of the formula  $W = 1.5 \times 700 (L + 40)$ , where L is the distance between the centers of the front and rear axles of a group. The values in line "B" and in the remaining tables are computed by applying the percentages prescribed in the tables' footnotes and are intended to increase the allowable weights based on wider axles and increased number of tires. Measured axle widths shall be rounded down to the nearest 1/4 foot when determining the appropriate table to use.

Note: The Department must review each possible axle group that can exist within an 18-foot distance. Axles of different configurations of width or number of tires must be prorated within the total group load in determining any allowed increase over the basic formula weight.

Note: Tire width is measured from the outside of the tire to outside of tire, this does not include the tire bulge.

**Notices of Supplemental Proposed Rulemaking**

**R17-6-412. Highway-specific Overdimensional Permitted Vehicle Restrictions**

Under A.R.S. § 28-7045, the following highway-use restrictions on transport by overdimensional permitted vehicles apply:

1. Permanent highway restrictions.  
A permittee of an overdimensional vehicle or load shall not access routes according to the provisions prescribed in Table 4.
2. Temporary highway restrictions.  
The Department may temporarily restrict highway access to overdimensional permit transport for no more than 12 months, due to a construction or maintenance project. A permittee shall check daily for changes in temporary highway restrictions:
  - a. In electronic format at internet address: ~~www.azfms.com/HCRS~~ www.az511.com, and selecting “Closures and Restrictions” or
  - b. By direct telephone communication with a highway project engineer in an ADOT district office in oversight of a permittee’s applicable transport route as follows:
    - i. Flagstaff: ~~(928) 774-1491~~ (928) 779-7547
    - ii. Globe: (928) 425-7638
    - iii. Holbrook: (928) 524-6801
    - iv. Kingman: (928) 757-5828
    - v. Phoenix: For the Phoenix metropolitan area, a permittee shall check with both the Phoenix Construction and Maintenance districts.
      - (1) Phoenix Maintenance: (602) 712-6664
      - (2) Phoenix Construction: (602) 712-8965
    - vi. Prescott: ~~(928) 445-5391~~ (928) 777-5860
    - vii. Safford: (928) 428-5470
    - viii. Tucson: ~~(520) 620-5416~~ (520) 620-5412
    - ix. Yuma: (928) 317-2100

MP – Milepost    Jct – Junction of Routes    F/R – Escorts at Front and Rear

**Table 4. Permanent Overdimensional Vehicle Highway Restrictions**

<u>Route Type</u>	<u>Route #</u>	<u>Restriction Criteria</u>	<u>Special Movement</u>	<u>Maximum Height</u>	<u>Maximum Length</u>	<u>At or over a width of</u>	<u>Maximum Weight (in lbs)</u>
<u>Interstate</u>	<u>8</u>	<u>All of route</u>	<u>See <del>R17-6-211,</del> R17-6-405, R17-6-409</u>				
<u>Interstate</u>	<u>10</u>	<u>All of route</u>	<u>See <del>R17-6-211,</del> R17-6-405, R17-6-409</u>				
<u>Interstate</u>	<u>10</u>	<u>MP 205.45 (Battaglia underpass)</u>		<u>15’ 9”</u>			
<u>Interstate</u>	<u>10</u>	<u>Eastbound at MP 289.35 (Pantano Railroad underpass)</u>		<u>15’</u>			
<u>Interstate</u>	<u>10</u>	<u>Westbound at MP 289.35 (Pantano Railroad underpass)</u>		<u>15’ 3”</u>			
<u>Interstate Business</u>	<u>10</u>	<u>MP 305.79 (SR 80 underpass)</u>		<u>14’</u>			
<u>Interstate Business</u>	<u>10</u>	<u>MP 305.85 (SP Railroad underpass)</u>		<u>14’ 3”</u>			
<u>Interstate</u>	<u>15</u>	<u>All of route</u>	<u>See <del>R17-6-211,</del> R17-6-405, R17-6-409</u>				

Notices of Supplemental Proposed Rulemaking

<u>Route Type</u>	<u>Route #</u>	<u>Restriction Criteria</u>	<u>Special Movement</u>	<u>Maximum Height</u>	<u>Maximum Length</u>	<u>At or over a width of</u>	<u>Maximum Weight (in lbs)</u>
Interstate	15	LCVs only - All of route requires Class E (See R17-6-206, Table 2)			92'		111,000
Interstate	15	LCVs only – All of route requires Class E (See R17-6-206, Table 2)			105'		129,000
Interstate	17	All of route	<del>See R17-6-211, R17-6-405, R17-6-409</del>				
Interstate	17	Southbound at MP 293.26 (Cornville/Mcquireville underpass)		14' 11"			
Interstate	17	19th Avenue to Buckeye Road		14'			
Interstate	19	All of route	<del>See R17-6-211, R17-6-405, R17-6-409</del>				
Interstate	40	All of route	<del>See R17-6-211, R17-6-405, R17-6-409</del>				
Interstate Business	40	Jct I-40 (West Flagstaff Traffic Interchange) to Jct US 89				12' requires F/R	
Interstate Business	40	MP 142.18 (Seligman GS)		15' 3"			
Interstate Business	40	MP 142.21 (SF Railroad underpass)		15' 3"			
Interstate Business	40	MP 165.98 (ATSF Railroad underpass)		14' 10"			
Interstate Business	40	MP 195.96 (SP Railroad underpass)		13' 9"			
State	51	All of route	<del>See R17-6-211, R17-6-405, R17-6-409</del>				
US	60	Wickenburg to Florence Junction	<del>See R17-6-211, R17-6-405, R17-6-409</del>				
US	60	Florence Junction to Globe			80'+ unarticulated vehicle requires F/R; 110'+ articulated vehicle requires F/R	11' requires F/R	
US	60	MP 228.13 (Queen Creek Tunnel)		14'			

**Notices of Supplemental Proposed Rulemaking**

<u>Route Type</u>	<u>Route #</u>	<u>Restriction Criteria</u>	<u>Special Movement</u>	<u>Maximum Height</u>	<u>Maximum Length</u>	<u>At or over a width of</u>	<u>Maximum Weight (in lbs)</u>
US	60	<u>Salt River Canyon to Show Low</u>			80'+ unarticulated vehicle requires F/R; 110'+ articulated vehicle requires F/R	12' requires F/R	
US	60	<u>Jct SR 61 to Jct US 180</u>				12' requires F/R	
US	60	<u>Eastbound at MP 110.24 (Wickenburg Railroad underpass)</u>		13' 11"			
US	60	<u>Westbound at MP 110.24 (Frontier Street underpass)</u>		13' 7"			
US	61	<u>Jct US 60 to Jct US 180</u>				12' requires F/R	
State	61	<u>Jct US 191 to State Line</u>				10' requires F/R	
State	64	<u>MP 237.1 to Jct US 89</u>				12' requires F/R	
US	64	<u>MP 470 to MP 465.2 requires Class E (See R17-6-206 Table 2)</u>			92'		123,500
State	67	<u>MP 579.36 to North Rim (Seasonal restriction Nov. 15 through May 15)</u>					20,000
State	67	<u>Jct US 89A to North Rim</u>				12' requires F/R	
State	68	<u>Jct US 93 to Jct SR 95</u>	<u>See R17-6-211, R17-6-405, R17-6-409</u>				
State	69	<u>Jct I-17 to Prescott</u>	<u>See R17-6-211, R17-6-405, R17-6-409</u>				
US	70	<u>MP 253.63 (Pinal SP Railroad)</u>		15' 8"			
State	71	<u>Jct US 60 to Jct US State 89</u>				12' requires F/R	
State	72	<u>Jct SR 95 to Jct US 60</u>				12' requires F/R	
State	73	<u>Jct US 60 to MP 334.72</u>				10' requires F/R	
State	77	<u>MP 109.15 (San Manuel overpass)</u>		14'			



*Arizona Administrative Register*  
**Notices of Supplemental Proposed Rulemaking**

<u>Route Type</u>	<u>Route #</u>	<u>Restriction Criteria</u>	<u>Special Movement</u>	<u>Maximum Height</u>	<u>Maximum Length</u>	<u>At or over a width of</u>	<u>Maximum Weight (in lbs)</u>
State	77	MP 119.15 (San Manuel overpass)		14' 1"			
State	77	Winkelman to Jct US 70			80'+ unarticulated vehicle requires F/R; 110'+ articulated vehicle requires F/R	12' requires F/R	
State	77	Show Low to Holbrook				12' requires F/R	
State	78	Jct SR 75 and US 191 to State Line				12' requires F/R	
State	80	MP 317.65 (Tombstone Pedestrian underpass)		15' 2"			
State	80	MP 343.57 (Lowell underpass)		12' 11"			
State	80	MP 366.10 (Douglas Railroad underpass)		12' 7"			
State	80	Douglas to New Mexico State Line				12' requires F/R	
State	82	Sonoita to Jct SR 80				12' requires F/R	
State	83	MP 3.19 to Sonoita				10' requires F/R	
State	83	Sonoita to Jct I-10				12' requires F/R	
State	84	MP 177.67 (SP Railroad underpass)		14'			
State	85	International Boundary to Ajo				12' requires F/R	
State	85	MP 0.38 (SP Railroad underpass)		14' 8"			
State	85	MP 0.57 (I-8 Westbound overpass)		15"			
State	85	MP 0.58 (I-8 Eastbound overpass)		15'			
State	85	MP 120.41 (Interstate Business 8 underpass – detour available)		15' 6"			
State	86	Why (Jct SR 85) to Jct SR 286 (Coordinate with Tohono O'odham Police)				12' requires F/R	

**Notices of Supplemental Proposed Rulemaking**

<u>Route Type</u>	<u>Route #</u>	<u>Restriction Criteria</u>	<u>Special Movement</u>	<u>Maximum Height</u>	<u>Maximum Length</u>	<u>At or over a width of</u>	<u>Maximum Weight (in lbs)</u>
State	87	Jct US 60 to Payson	See <del>R17-6-211</del> , R17-6-405, R17-6-409				
State	87	MP 254 (Payson) to Winslow				12' requires F/R	
State	88	Idaho Road to MP 242.04 (Roosevelt)				Over 8' requires class C permit	
State	88	MP 220.6 to MP 226.6			40'		20,000
State	88	MP 209.5 (Willow Creek Bridge)		14'			
State	88	MP 222 to MP 224.3 ONE LANE ROAD RESTRICTION					
<del>US</del> State	89	Jct US 93 to Prescott City limits				12' requires F/R	
<del>US</del> State	89	MP 295 to MP 308			40'	Over 8' requires class C permit	
US	89	MP 549.54, Glen Canyon Bridge (Requires that vehicle come to complete stop, then proceed at 5 m.p.h. with no gear shifting)					150,000
US	89	MP 552 to MP 532, LCVs require Class E (See R17-6-206, Table 2)			92'		111,000
<del>US</del> State	89A	Jct <del>US</del> State 89 (Prescott) to MP 331				12' requires F/R	
<del>US</del> State	89A	MP 319.01 (Santa Fe Railroad underpass)		13' 11"			
<del>US</del> State	89A	MP 331 to MP 346			50'	Over 8' requires class C permit	
<del>US</del> State	89A	Jct SR 179 (Sedona) to Flagstaff				10' requires F/R	
US	89A	Jct US 89 to MP 548 (Cliffd-weller's Lodge)				10' requires F/R	
US	89A	MP 548 to Jacob Lake				Over 8'6" requires class C permit	
US	89A	Jacob Lake to Fredonia				12' requires F/R	

*Arizona Administrative Register*  
**Notices of Supplemental Proposed Rulemaking**

<u>Route Type</u>	<u>Route #</u>	<u>Restriction Criteria</u>	<u>Special Movement</u>	<u>Maximum Height</u>	<u>Maximum Length</u>	<u>At or over a width of</u>	<u>Maximum Weight (in lbs)</u>
US	89A	MP 610 to MP 579.4, LCVs require Class E (See R17-3-206, Table 2)			92'		123,500
State	90	Jct I-10 to Sierra Vista	See <del>R17-6-211</del> , R17-6-405, R17-6-409		92'		123,500
US	93	<b>Post marker 3 to Hoover Dam – No overdimensional vehicle permitted</b>					
US	93	MP 17 to MP 3				10' requires F/R	
US	93	Jct I-40 to Jct SR 68	See <del>R17-6-211</del> , R17-6-405, R17-6-409				
US	93	Wikieup to Jct SR 97				12' requires F/R	
State	95	Jct SR 68 to city limits of Bullhead City	See <del>R17-6-211</del> , R17-6-405, R17-6-409				
State Spur	95	MP 144.83 (Colorado River Bridge)					80,000
State	96	Jct SR 97 to Hillside				10' requires F/R	
State	98	Jct US 89 to MP 320, LCVs require Class E (see R17-6-206, Table 2)			92'		111,000
State	98	MP 361.39 (electrical wire near Jct US 160)		16'6"			
State	101	All of route	See <del>R17-6-211</del> , R17-6-405, R17-6-409				
State	160	MP 470 to MP 394, LCVs require Class E (see R17-6-206, Table 2)			92'		123,500
US	163	Jct US 160 (Kayenta) to State Line				12' requires F/R	
US	163	MP 410 to MP 394.5, requires Class E (See R17-6-206, Table 2)			92'		123,500
State	170	Jct US 70 to Route End				12' requires F/R	
State	177	Winkelman to Jct US 60 (Superior)				12' requires F/R	
State	179	Jct I-17 to Sedona				12' requires F/R	

**Notices of Supplemental Proposed Rulemaking**

<u>Route Type</u>	<u>Route #</u>	<u>Restriction Criteria</u>	<u>Special Movement</u>	<u>Maximum Height</u>	<u>Maximum Length</u>	<u>At or over a width of</u>	<u>Maximum Weight (in lbs)</u>
US	<u>180</u>	<u>Jct SR 64 to Flagstaff</u>				<u>12' requires F/R</u>	
US	<u>180</u>	<u>Jct US 60 (Springerville) to Jct US 191 (Alpine)</u>				<u>12' requires F/R</u>	
US	<u>180</u>	<u>Jct SR 77 to Jct SR 61</u>				<u>12' requires F/R</u>	
State	<u>181</u>	<u>Jct US 191 to MP 65.04 (Chiricahua Nat'l Monument)</u>				<u>12' requires F/R</u>	
State	<u>186</u>	<u>Dos Cabezas (MP 342.92) to Jct SR 181</u>				<u>10' requires F/R</u>	
State	<u>187</u>	<u>Jct 387 to Jct SR 87</u>				<u>12' requires F/R</u>	
State	<u>188</u>	<u>MP 250 to MP 260</u>				<u>12' requires F/R</u>	
US	<u>191</u>	<u>Jct I-40 to Jct US 160</u>				<u>12' requires F/R</u>	
US	<u>191</u>	<u>MP 173.18 to Jct US 180 (Alpine)</u>			<u>40'</u>	<u>Over 8' requires class C permit</u>	
State	<u>202</u>	<u>All of route</u>	<u>See <del>R17-6-211</del>, R17-6-405, R17-6-409</u>				
State	<u>260</u>	<u>Jct SR 87 (Payson) to Star Valley</u>	<u>See <del>R17-6-211</del>, R17-6-405, R17-6-409</u>				
State	<u>260</u>	<u>Jct SR 87 (Payson) to MP 339</u>				<u>12' requires F/R</u>	
State	<u>260</u>	<u>MP 358 to MP 410</u>			<u>80'+ requires F/R</u>	<u>12' requires F/R</u>	
State	<u>261</u>	<u>MP 394.4 to 412.7</u>					<u>35,000</u>
State	<u>264</u>	<u>Jct US 160 to MP 471.29</u>				<u>12' requires F/R</u>	
State	<u>266</u>	<u>Jct US 191 to MP 123.8</u>				<u>12' requires F/R</u>	
State	<u>273</u>	<u>All of route</u>			<u>80'+ requires F/R</u>	<u>10' requires F/R</u>	<u>20,000</u>
State	<u>286</u>	<u>International Boundary to Jct SR 86</u>				<u>12' requires F/R</u>	
State	<u>288</u>	<u>Jct SR 188 to Route End (Near Young)</u>			<u>70'</u>	<u>Over 8' requires class C permit</u>	

**Notices of Supplemental Proposed Rulemaking**

<u>Route Type</u>	<u>Route #</u>	<u>Restriction Criteria</u>	<u>Special Movement</u>	<u>Maximum Height</u>	<u>Maximum Length</u>	<u>At or over a width of</u>	<u>Maximum Weight (in lbs)</u>
State	<u>288</u>	<u>MP 262.44 (Salt River Bridge)</u>		<u>12'</u>			<u>80,000</u>
State	<u>289</u>	<u>Jct I-19 to Route End</u>				<u>10' requires F/R</u>	
State	<u>347</u>	<u>Jct SR 84 to Jct I-10</u>	<u>See R17-6-211, R17-6-405, R17-6-409</u>				
State	<u>366</u>	<u>MP 115 to Route End (Graham Peak)</u>			<u>40'</u>	<u>Over 8' requires class C permit</u>	
State	<u>377</u>	<u>Jct SR 277 to Jct SR 77</u>				<u>12' requires F/R</u>	
State	<u>386</u>	<u>Jct SR 86 to Kitt Peak</u>				<u>10' requires F/R</u>	
State	<u>389</u>	<u>LCVs only - All of route requires Class E (See R17-6-206, Table 2)</u>			<u>92'</u>		<u>123,500</u>
State	<u>473</u>	<u>Jct SR 260 to Route End (Hawley Lake)</u>			<u>60'+ requires F/R</u>	<u>10' requires F/R</u>	<u>20,000</u>
State	<u>564</u>	<u>Jct US 160 to Route End</u>				<u>12' requires F/R</u>	

**ARTICLE 6. MANUFACTURED HOME PERMIT SPECIAL PROVISIONS**

**R17-6-601. Self-issue Prepaid Permit Enforcement**

Upon examination of a manufactured home self-issue prepaid permit, a law enforcement officer shall:

- A.** Void any incorrect or incomplete permit, and
- B.** Prohibit any further movement of an invalidly permitted vehicle until the Arizona Central Commercial Permits office issues a valid replacement permit.

**R17-6-602. Penalties**

- A.** The Division shall suspend for one year a transporter's privilege to use self-issue prepaid manufactured home permits if the transporter fails to comply with:
  - 1. An applicable safety requirement under R17-6-301 through R17-6-307; or
  - 2. An applicable transport restriction under R17-6-401 through R17-412.
- B.** The Division shall permanently revoke a transporter's privilege to use self-issue prepaid manufactured home permits upon the transporter's subsequent failure to comply with a required provision under subsection (A).